

# Air coolers FC38

## Standard

### Cu/Al-R404A/Coolants

GEA Heat Exchangers

Goedhart FC38S



Goedhart FC38D



Goedhart FC38L



# General features

## Casing

- Standard refrigerant connections are fixed on the left hand side of the unit when looking with the direction of the air flow.
- Construction suitable for mounting to the ceiling.
- The FC38 casing is made from galvanized sheet steel, with exception of:
  - FC38S drip tray is hinged and made from light aluminum.
  - FC38D has a fixed galvanized drip tray.
  - FC38L drip tray is hinged and made from light aluminum.
- Goedhart FC38L air cooler is executed with a short splash plate as standard.
- The casing has a corrosion resistant white epoxy spray finish (RAL 9003).
- Almost all fixing materials are made of stainless steel to prevent corrosion.
- A possible hot gas spiral or electric defrost elements will be fixed to the bottom side of the coil

## Options

Extra opties	FC38S	FC38D	FC38L
Hot gas defrost	•		
Warm glycol defrost	•		
Fan heating	•		•
Splash plate	•		•
Zuigende uitvoering	•		
Draw through execution	•		
StSt tubes	•	•	•
StSt casing	•	•	•
Goldlack fins	•	•	•
Almg fins	•	•	•
Insulated drip tray	•		

## P.E.D.

All air coolers produced by Goedhart comply with the Pressure Equipment Directive 97/23/EC. PED certificates can be downloaded from [www.goedhart.nl](http://www.goedhart.nl).

## Guarantee

Goedhart gives in conformity with her general conditions of delivery the following guarantee periode on the Goedhart FC38 air coolers:

- within a 12 month period of product use
- at the latest within 18 months after the time of delivery.

## Sound data

The mean sound pressure (LpA @ 3m ± 2 dB (A)) each air cooler is a calculated indication value according to the EN13487 standard parallel pipe. Goedhart uses the fan manufacturer's sound power level (LwA) at the inlet side of the fan. Changes to or by the fan or the product, affect the sound, in these cases, consult the manufacturer for the new indication value. In critical sound requirements, we advise you to consult an expert.

## Defrost systems

For room temperatures where ripe formation can be expected and where the coil can not be defrosted by the room air, electrical or hot gas defrost is necessary

### Electrical defrost

On request FC38 can be provided with electrical defrost. FC38 is always delivered with heavy defrost. The heater elements are rated for 220/240 V and are 400/420 V with zero wire supply. The stainless steel heater elements are fitted in the coil block in inner tubes which form a highly conductive medium between the heaters and the fins. In the drip-tray, the heater elements are fitted to the bottom side of the underside of the aluminum inner tray. The heater elements in the coil block are removable from the header side of the unit, whilst the tray heater elements can be removed once the outer tray has been taken off.

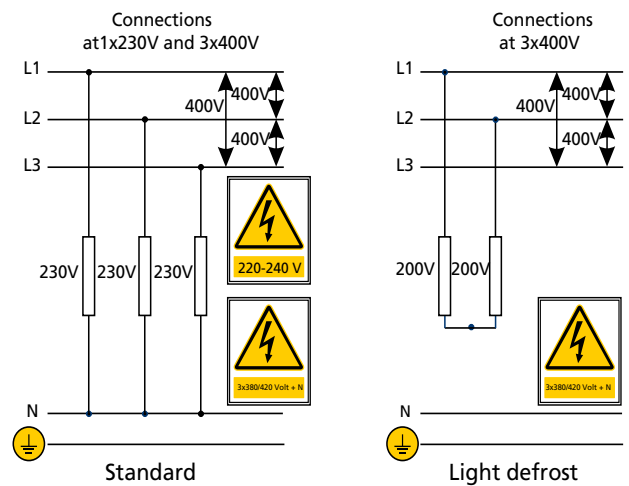

### Hot gas defrost

The coil block is suited for hot gas defrost (hot gas supply through the suction header). The drip tray can be provided with a copper hot gas spiral, which is enclosed in special aluminum profiles, which are rigidly secured to underside of the aluminum inner tray.

## Mounting & Maintenance

FC38 is delivered in a wooden crate. FC38S will be delivered with the separate drip-tray. When crated, FC38 can be handled by crane or fork-lift truck, which makes it very easy to mount. The drip tray of the FC38S is delivered separately. For maintenance and instructions see our manual delivered on order or can be downloaded from our web site [www.goedhart.nl](http://www.goedhart.nl).



## Fans

FC38 aircoolers are executed with 2 fan manufactures:

EBM : Ø250, Ø300, Ø350, Ø400 and Ø450

Ziehl Abegg : Ø500

(We reserve the right to alter the manufacturer)

The fans are suitable for operation in air temperatures between -30 °C to +40 °C. When the air temperature is lower than -30 °C, special fans are needed. These special fans have a longer delivery time. The protection class is IP44. The fans are neither available with stainless steel protection guards nor stainless steel arms.

The technical data in the table are the same as on the motor name plates and is valid for an air temperature of +20 °C. Also the data are given for working in an air temperature of 0 °C and -20 °C.

### 1x230V-50Hz

The standard connection tension for the EBM fans is 230V-50Hz-1 phase for the fan diameters Ø250, Ø300, Ø350, Ø400 en Ø450.

The fan motors are standard equipped with internally connected thermo-contacts.

### 3x400V-50Hz

The EBMØ450 fan is on request available in 230/400V-50Hz-3 phase. The fan is executed with a thermal contact.

The standard connection voltage for the Ziehl Abegg Ø500 is 400/690V-50Hz- 3phase (on request 230V-50Hz-1 phase). This fan is equipped with thermo contacts.

Fan type	Values at 1x230V-50Hz								Sound power indication each fan LwA (+/-2dB(A))
	Speed	Input	+20°C		0°C		-20°C		
			FLC	Start	FLC	Start	FLC	Start	
rpm	[W]	[A]	[A]	[A]	[A]	[A]	[A]	[dBA]	
<b>4 pole fans (1500 rpm nominal)</b>									
S4E250	400	45	0,21	0,35	0,23	0,38	0,24	0,41	69
S4E300	1390	73	0,32	0,60	0,44	0,65	0,46	0,70	74
S4E350	1400	130	0,58	1,30	0,63	1,40	0,67	1,51	79
S4E400	1430	160	0,73	1,90	0,79	2,05	0,85	2,20	82
S4E450*	1390	245	1,10	2,70	1,19	2,92			85
S4E450	1350	480	2,20	5,80	2,27	6,26	2,44	3,13	85
FE050	1210	770	3,40	7,40	3,67	7,99	3,94	8,58	81

### 6 pole fans (1000 rpm nominal) \*

S6E400	950	120	0,55	0,90	0,59	0,97			72
S6E450	920	165	0,80	1,36	0,85	1,47			77

Fan type	Values at 3x230/400V-50Hz								Sound pressure level each fan **
	Speed	Input	+20°C		0°C		-20°C		
			FLC	Start	FLC	Start	FLC	Start	
rpm	[W]	[A]	[A]	[A]	[A]	[A]	[A]	[dBA]	
<b>4 pole fans (1500 rpm nominal)</b>									
S4D450	1330	585	1,10	3,00	1,18	3,24	1,28	3,48	85
FE050	1330	790	1,45	5,20	1,57	5,62	1,68	6,03	83

\* = Only FC38D

### ebm-papst 1x230V-50Hz

L= blue  
N=black  
Z=brown

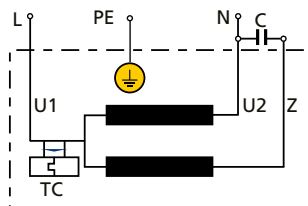

### ebm-papst 3x230/400V-50Hz

U1=black  
V1=blue  
W1=brown  
U2=green  
V2=white  
W2=yellow

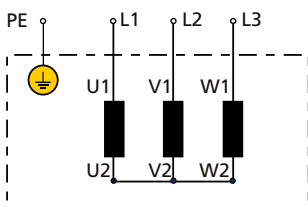

### Ziehl Abegg 3x400/690V

U1 =brown  
V1 =blue  
W1=black  
U2 =red  
V2 =grey  
W2=orange  
TB =white

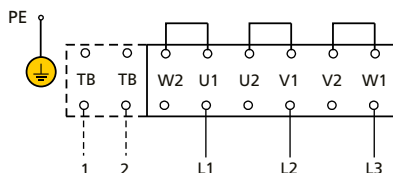

# Correction factors

## Correction factors DT1 (=Air-on)

The nominal capacities of the Goedhart FC38i(dx) and FC38p(dx) air coolers are based on R-404A direct expansion, DT1 and a RH of 85%. DT1 is the difference between air-on temperature and the evaporation temperature of the cooler. The evaporation temperature is the saturated temperature corresponding to the pressure at the suction outlet of the cooler.

The nominal capacities:

- (SC1)  $t_o = 0\text{ °C}$  and DT1= 10 K
- (SC2)  $t_o = -8\text{ °C}$  and DT1= 8 K
- (SC3)  $t_o = -25\text{ °C}$  and DT1= 7 K

Correction factors for various evaporation temperatures and temperature differences (DT1) are as indicated in the tables below. The requested capacity must be multiplied by a correction factor from the table, so that a cooler with the resulting nominal capacity can be chosen from the selection tables.

**Q nominal = factor x Q requested**

R404A										
DT1	Evaporation temperature (°C)									
K	+7	+6	+5	+4	+3	+2	+1	0	-1	-2
6	1,81	1,81	1,82	1,82	1,83	1,83	1,84	1,84	1,84	1,85
7	1,49	1,50	1,50	1,50	1,51	1,51	1,52	1,52	1,52	1,53
8	1,27	1,28	1,28	1,29	1,29	1,29	1,30	1,30	1,30	1,31
9	1,10	1,10	1,11	1,11	1,12	1,12	1,13	1,13	1,13	1,14
10	0,97	0,98	0,98	0,99	0,99	0,99	1,00	1,00	1,00	1,01
11	0,88	0,88	0,88	0,89	0,89	0,90	0,90	0,90	0,90	0,91
12	0,79	0,79	0,79	0,80	0,80	0,81	0,81	0,81	0,81	0,82

**SC1** DT1 = 10K  
Air on = 10°C (0/+10°C)

R404A										
DT1	Evaporation temperature (°C)									
K	-3	-4	-5	-6	-7	-8	-9	-10	-11	-12
6	1,30	1,34	1,38	1,42	1,42	1,43	1,43	1,43	1,44	1,44
7	1,04	1,07	1,10	1,14	1,17	1,18	1,18	1,18	1,19	1,19
8	0,86	0,88	0,91	0,94	0,97	1,00	1,00	1,01	1,01	1,01
9	0,75	0,75	0,77	0,79	0,82	0,84	0,87	0,87	0,87	0,88
10	0,66	0,66	0,66	0,68	0,70	0,72	0,74	0,77	0,77	0,77
11	0,59	0,59	0,59	0,59	0,61	0,63	0,65	0,67	0,69	0,69
12	0,54	0,54	0,54	0,54	0,54	0,55	0,57	0,58	0,60	0,62

**SC2** DT1 = 8K  
Air on = 0°C (-8/0°C)

R404A										
DT1	Evaporation temperature (°C)									
K	-21	-22	-23	-24	-25	-26	-27	-28	-29	-30
6	1,20	1,20	1,21	1,21	1,21	1,22	1,22	1,23	1,23	1,23
7	0,99	0,99	0,99	1,00	1,00	1,00	1,00	1,01	1,01	1,02
8	0,84	0,84	0,84	0,85	0,85	0,85	0,85	0,86	0,86	0,86
9	0,73	0,73	0,73	0,73	0,73	0,74	0,74	0,74	0,74	0,75
10	0,64	0,64	0,64	0,64	0,65	0,65	0,65	0,65	0,66	0,66
11	0,57	0,57	0,57	0,58	0,58	0,58	0,58	0,58	0,59	0,59
12	0,52	0,52	0,52	0,52	0,52	0,52	0,53	0,53	0,53	0,53

**SC3** DT1 = 7K  
Air on = -18°C (-25/-18°C)

## Capacity optimization

To achieve the best possible combination of application, refrigerant and capacity, Goedhart can optimise the coil circuiting, depending on the specific conditions under which the products will be used. FC38 is a standard product to ensure shorter delivery times. The circuiting of these evaporators has been optimized according to the most commonly used coolants/refrigerants and conditions. Specific applications can vary from this, our sales department is there to assist you in selecting the best circuiting for your application.

## Correction factors for coolants

The nominal capacities of the Goedhart FC38p(G) air coolers are based on an air-on temperature of 12°C, a RH of 85% and:

- Water : in / out temperatuur = +1/+5°C
- E-Glycol : in / out temperatuur = - 2/+3°C
- P-Glycol : in / out temperatuur = - 2/+3°C
- Pekasol : in / out temperatuur = - 2/+3°C
- Freezium : in / out temperatuur = - 2/+3°C

Correction factors for various air-on temperatures and refrigerants or secondary coolants are as indicated in the tables below. The requested capacity must be multiplied by a correction factor from the table, so that a cooler with the resulting nominal capacity can be chosen from the selection tables.

**Q nominal = faktor x Q requested**

Water										
in/out	Air-on temperature (°C)									
°C	+8	+9	+10	+11	+12	+13	+14	+15	+16	
1 / 5	1,99	1,59	1,32	1,14	1,00	0,88	0,78	0,72	0,66	
2 / 6		1,95	1,57	1,30	1,12	0,98	0,87	0,78	0,71	
3 / 7			1,92	1,54	1,28	1,11	0,97	0,86	0,77	
4 / 8				1,94	1,56	1,31	1,13	0,98	0,87	
5 / 9					1,86	1,49	1,25	1,07	0,94	

E-Glycol 28%										
in/out	Air-on temperature (°C)									
°C	+8	+9	+10	+11	+12	+13	+14	+15	+16	
-2 / 3	1,81	1,46	1,34	1,16	1,00	0,88	0,82	0,81	0,69	
-1 / 4	2,35	1,72	1,41	1,28	1,10	0,96	0,85	0,79	0,75	
0 / 5	2,43	2,30	1,64	1,40	1,24	1,06	0,93	0,84	0,76	
1 / 6		2,38	2,28	1,59	1,37	1,21	1,05	0,92	0,82	
2 / 7			2,28	2,09	1,55	1,35	1,17	1,03	0,91	

P-Glycol 28%										
in/out	Air-on temperature (°C)									
°C	+8	+9	+10	+11	+12	+13	+14	+15	+16	
-2 / 3	1,66	1,45	1,26	1,11	1,00	0,91	0,83	0,76	0,70	
-1 / 4	2,00	1,65	1,42	1,24	1,11	1,01	0,90	0,81	0,77	
0 / 5	2,48	1,94	1,65	1,41	1,23	1,14	1,00	0,91	0,85	
1 / 6		2,46	1,97	1,64	1,42	1,29	1,12	1,00	0,92	
2 / 7			2,45	1,96	1,63	1,64	1,28	1,11	1,00	

Pekasol 50%										
in/out	Air-on temperature (°C)									
°C	+8	+9	+10	+11	+12	+13	+14	+15	+16	
-2 / 3	1,68	1,42	1,26	1,11	1,00	0,90	0,82	0,77	0,70	
-1 / 4	2,02	1,65	1,42	1,24	1,10	0,98	0,89	0,81	0,76	
0 / 5	2,39	1,96	1,62	1,39	1,22	1,07	0,96	0,87	0,80	
1 / 6		2,36	1,93	1,60	1,37	1,20	1,06	0,94	0,86	
2 / 7			2,32	1,89	1,57	1,35	1,18	1,05	0,94	

Freezium 24%										
in/out	Air-on temperature (°C)									
°C	+8	+9	+10	+11	+12	+13	+14	+15	+16	
-2 / 3	1,66	1,44	1,25	1,11	1,00	0,91	0,83	0,77	0,71	
-1 / 4	1,94	1,62	1,42	1,23	1,09	0,98	0,89	0,82	0,76	
0 / 5	2,38	1,91	1,59	1,39	1,21	1,07	0,97	0,88	0,81	
1 / 6		2,34	1,88	1,57	1,37	1,20	1,06	0,95	0,86	
2 / 7			2,30	1,86	1,55	1,35	1,18	1,05	0,94	

# F38Dp(dx) - R404A

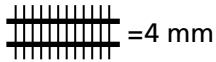

Type	Fan diameter	1x230V-50Hz-4 pole					1x230V-50Hz-6 pole					Surface	Connections		Weight	Internal volume
		SC1	SC2				SC1	SC2					I	K		
FC38D	mm	kW	kW	m <sup>3</sup> /h	dB(A)	kW	kW	m <sup>3</sup> /h	dB(A)	m <sup>2</sup>	mm	mm	kg	dm <sup>3</sup>		
6.1.30.4	1x300	3,7	2,4	1048	52					16	12	12	54	4		
6.1.35.4	1x350	5,8	3,9	1644	57					20	12	22	66	6		
6.2.30.4	2x300	7,7	5,2	2045	55					30	12	22	82	8		
6.2.35.4	2x350	10,4	7,0	3060	60					34	12	22	92	8		
6.2.40.4	2x400	17,4	11,8	4890	63	13,6	9,2	3434	53	61	16	28	123	14		
6.2.45.4	2x450	29,1	19,5	8674	68	22,2	15,2	5669	58	95	16	35	161	20		
6.3.30.4	3x300	11,9	8,1	3155	57					48	12	22	114	10		
6.3.35.4	3x350	14,5	9,7	4343	62					48	12	22	116	10		
6.3.40.4	3x400	26,3	17,6	7339	64	20,6	14,0	5156	54	91	16	35	169	20		
6.3.45.4	3x450	45,2	30,0	13139	69	34,1	23,1	8600	60	146	16	35	228	32		
6.4.30.4	4x300	15,5	10,4	4095	58					61	16	28	138	14		
6.4.35.4	4x350	19,2	12,8	5609	63					61	16	28	139	14		
6.4.40.4	4x400	32,4	21,6	9240	65	25,5	17,3	6439	55	110	16	35	200	24		

\* = Sound pressure indication (LpA) at 3 m distance each air cooler (+/- 2 dB(A)), free field conditions, according EN13487

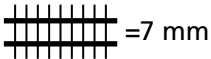

Type	Fan diameter	1x230V-50Hz-4 pole					1x230V-50Hz-6 pole					Surface	Connections		Weight	Internal volume
		SC1	SC2				SC1	SC2					I	K		
FC38D	mm	kW	kW	m <sup>3</sup> /h	dB(A)	kW	kW	m <sup>3</sup> /h	dB(A)	m <sup>2</sup>	mm	mm	kg	dm <sup>3</sup>		
6.1.30.7	1x300	3,2	2,2	1262	52					10	12	12	51	4		
6.1.35.7	1x350	4,8	3,2	2004	57					12	12	22	62	6		
6.2.30.7	2x300	6,4	4,3	2480	55					18	12	22	77	8		
6.2.35.7	2x350	8,7	5,8	3706	60					21	12	22	87	8		
6.2.40.7	2x400	14,2	9,4	5793	63	11,7	8,0	4197	53	36	12	22	114	14		
6.2.45.7	2x450	23,9	16,0	10019	68	18,9	12,8	6703	58	57	16	28	145	20		
6.3.30.7	3x300	10,2	6,9	3795	57					29	12	22	107	10		
6.3.35.7	3x350	12,4	8,2	5320	62					29	12	22	109	10		
6.3.40.7	3x400	21,7	14,5	8695	64	17,8	12,0	6299	54	55	16	28	154	20		
6.3.45.7	3x450	36,7	24,3	15125	69	28,8	19,4	10128	60	88	16	35	203	32		
6.4.30.7	4x300	13,0	8,7	4964	58					36	12	22	128	14		
6.4.35.7	4x350	15,9	10,5	6912	63					36	16	22	129	14		
6.4.40.7	4x400	27,2	18,1	11135	65	22,4	15,1	7999	55	66	16	28	181	24		

\* = Sound pressure indication (LpA) at 3 m distance each air cooler (+/- 2 dB(A)), free field conditions, according EN13487

# F38Dp(dx) - R404A

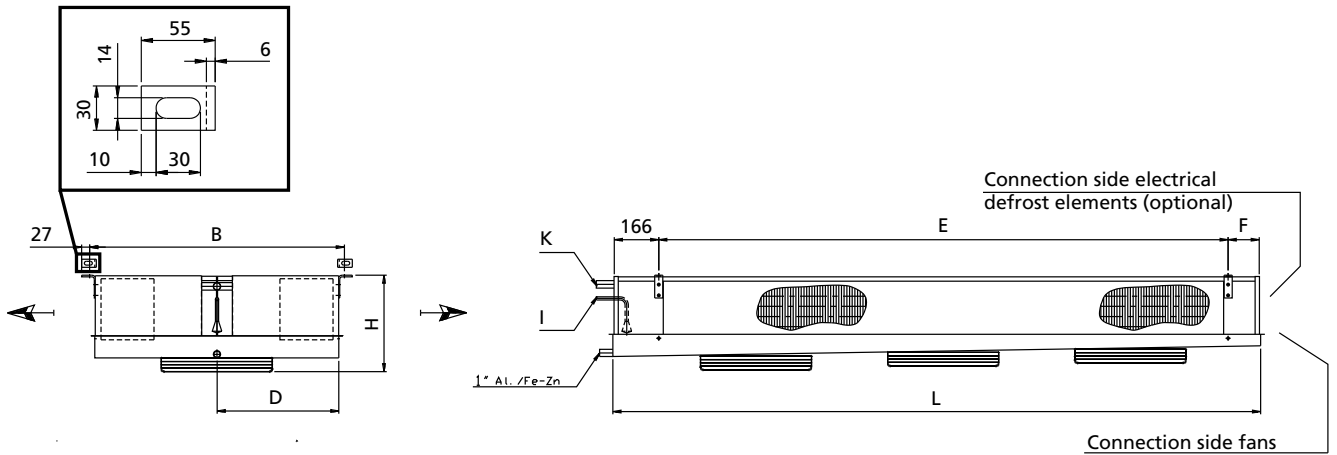

## Declarations

Connection $\leq 35$ mm	: Declaration of incorporation (SEP)
Connection 42mm and 54 mm	: module A
Group of fluid	: 2
PS	: 28 bar
TS	: +55 / -40 °C

Type	Dimensions						Electrical defrost at 3x400V-50Hz				Standard	Light	Dimensions & Electrical defrost		
	L	B	H	D	E	F	Coil block		Drip tray					kW	kW**
							number	O [mm]	number	O [mm]					
FC38D	mm	mm	mm	mm	mm	mm									
6.1.30.*	925	850	280	405	575	166	2x L=1600	132	2x L=1600	150	2,5				
6.1.35.*	1080	850	280	405	730	166	2x L=1900	132	2x L=1900	150	3,0				
6.2.30.*	1425	850	280	405	1075	166	2x L=2500	132	2x L=2500	150	4,1				
6.2.35.*	1570	850	280	405	1220	166	2x L=2800	132	2x L=2800	150	4,6				
6.2.40.*	1775	950	390	455	1425	166	4x L=3100	132	2x L=3400	150	8	6,1			
6.2.45.*	2025	1000	465	480	1675	166	4x L=3700	132	2x L=3700	150	9,3	7,0			
6.3.30.*	2025	850	280	405	1675	166	2x L=3700	132	2x L=3700	150	6,2				
6.3.35.*	2025	850	280	405	1675	166	2x L=3700	132	2x L=3700	150	6,2				
6.3.40.*	2475	950	390	455	2125	166	4x L=4600	132	2x L=4600	150	11,6	8,8			
6.3.45.*	2850	1000	465	480	2550	116	4x L=5500	132	2x L=5500	150	14,0	10,6			
6.4.30.*	2475	850	280	405	2125	166	2x L=4600	132	2x L=4600	150	7,8				
6.4.35.*	2475	850	280	455	2125	166	2x L=4600	132	2x L=4600	150	7,8				
6.4.40.*	2850	950	390	480	2550	116	4x L=5500	132	2x L=5500	150	14,0	10,6			